

ALLTAC INTEGRATED HDPU TGSi PAD TPP-H-36

INDICATOR DETAILS

RANGE	ALLSTAR
MATERIAL	BASF ELASTOLLAN
TYPE	THERMOPLASTIC H.D.P.U
FINISH	MOULDED

FEATURES

- HDPU
- 16 POINT CROWN DESIGN
- WORLD'S FIRST SELF CLEANING TACTILE INDICATOR
- UV STABLE
- PATENTED STAR DESIGN
- UNIQUE 300MM X 600MM SIZE
- RETRO-FIT APPLICATION
- AVAILABLE IN WITH PEEL & STICK

TESTING (PERFORMED BY CSIRO)

AS/NZ1428.4.1
CTAC Certification, Design for access and mobility - Tactile Indicators
Clause 2.3.2 Design Requirements: **Complies**

AS/NZS 4586 APENDIX A
WET PENDULUM 4S: **Y**

AS/NZS 4586 APENDIX D
OIL WET RAMP TEST: **R10**

AS/NZS 1428.4
WET & DRY LUMINOUS REFLECTANCE: **Colour Dependant**

ALLTAC

ALLTAC are manufacturers and distributors of quality Australian products

info@alltac.com.au
www.alltac.com.au

1300ALLTAC
1300 255 822

Allsafe products can be installed by our licensed contractors throughout Australia and overseas.

ALLTAC INTEGRATED HDPU TGSi PAD TPP-H-36

OPTIONS



BLACK



WHITE



YELLOW

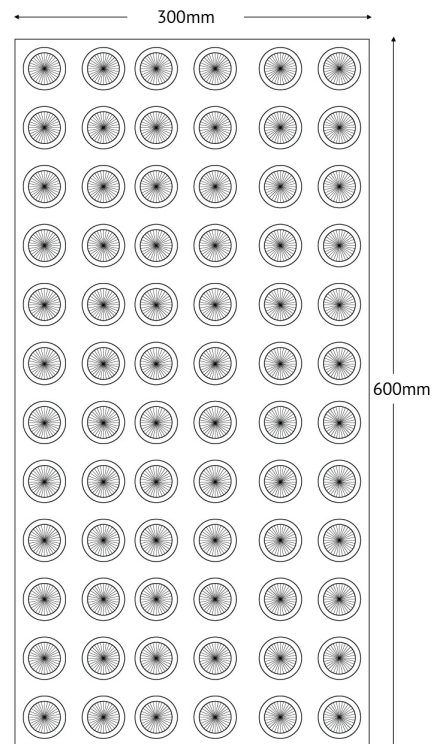
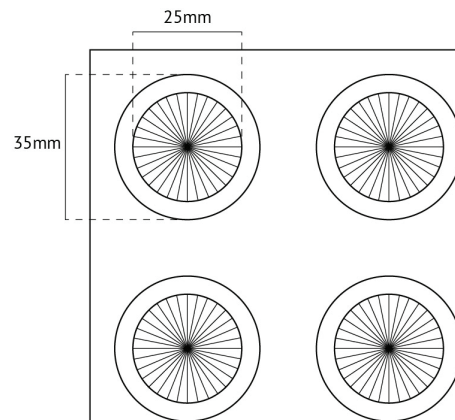

ALLTAC are manufacturers and distributors of quality Australian products

info@alltac.com.au
www.alltac.com.au

1300ALLTAC
1300 255 822

Allsafe products can be installed by our licensed contractors throughout Australia and overseas.